

*Instruction for work*  
*Betriebsanleitung*  
*List of spare parts*  
*Ersatzteilliste*



# SIP

# ROTO

175 D, 180 DS, 215 D, 220 DS, 255 D, 295 D

rotary disc mower      scheinmäher

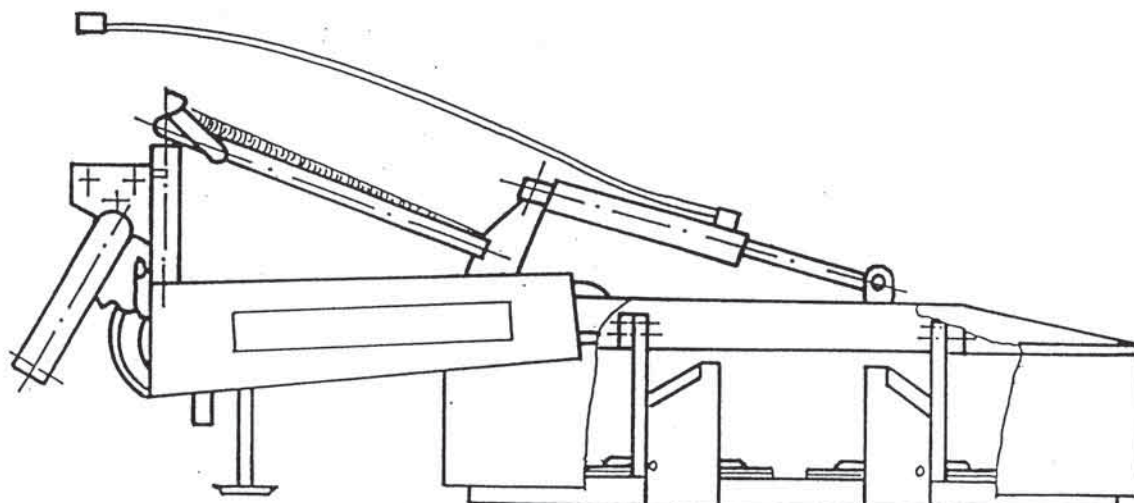

Ab masch. Nr.:

From mach Nr.:

ROTO 175 D = 431

ROTO 180 DS = 081

ROTO 215 D = 561

ROTO 220 DS = 061

ROTO 255 D = 421

ROTO 295 D = 181



# SIP

STROJNA INDUSTRIJA d.o.o.  
3311 Šempeter v Savinjski dolini  
Slovenija

2000  
Tel: +386 (063) 702 211

Fax: +386 (063) 702 131

702 134

153887511

No.on the figure Numer anzeichn.	Catalogue no. Katalog nummer	Description	Benennung	Quantity Stück
1	152926105-516.05.001.0	Hitch welded	Dreipunktaufhängung schw.	1
2	153618008-546.05.001.0	Neck	Scharnier	1
3	153840106-547.05.002.0	Lever	Hebel schw.	1
4	153739903-546.00.101.0	Hydraulic cylinder	Hydraulik Zylinder	A1
4	153927004-547.05.006.0	Hydraulic cylinder	Hidraulik	B1
5	153846501-547.05.021.0	Link welded	Verbindung schw.	1
6	151025714-510.05.041.1	Protector	Sicherung	1
7	153679905-546.05.016.0	Cap	Siegerungskappe	1
8	153885709-547.05.023.0	Link 2	Verbindung 2	1
9	151026302-510.05.046.0	Limitateur	Distanzrohr	1
10	153619301-TN 03	Distance sleeve	Distanzbüchse	1
11	151026400-510.05.047.0	Distance sleeve	Distanzbüchse	1
12	151026605-510.05.049.0	Sleeve	Büchse	1
13	151026703-TN 01	Washer	Scheibe	2
14	151026801-510.05.051.0	Bolt	Bolzen	1
15	152663308-156.03.021.0	Bolt	Bolzen	1
16	153618801-546.05.007.0	Bolt 5	Bolzen 5	A1
16	153927102-547.05.010.0	Bolt 5	Bolzen 5	B1
17	152593009-502.11.035.0	Bolt	Bolzen	1
18	152088207-457.07.096.0	Bolt	Bolzen	1
19	152737232-516.05.056.2	Bolt	Bolzen	1
20	151027409-510.05.056.0	Spring	Zugfeder	1
21	153245714-342.00.015.1	Chain	Kette kpl.	1
22	151027604-510.05.057.0	Plastic sleeve	Elastikbüchse	2
23	150272403-	Protection pin	Sicherungstift	1
24	151027800-TN 01	Washer	Scheibe	1
25	152448711-516.05.052.1	Bolt	Bolzen	1
26	152010807-516.05.026.0	Limitateur	Distanzrohr	1
27	152011003-516.05.032.0	Hook	Haken schw.	1
28	152011405-516.05.037.0	Bolt	Bolzen	1
29	150296708-152.06.039.0	String	Schnur	1
30	151121002-M39.06.00.22	Spring	Feder	1
31	152011600-516.05.040.0	Tube	Rohr	1
32	152011708-516.05.045.0	Eye	Ohr schw.	2
33	152926213-516.05.054.1	Plastic string	Seil kpl.	1
34	150019401	Clamp 9/11	Klemme 9/11	2
35	150288708	Screw M10x95 Zn	Schraube M10x95 Zn	1
36	150320405	Screw M10x100 Zn	Schraube M10x100 Zn	1
37	150008100	Screw M10x40 8.8	Schraube M10x40 8.8	1
38	150146005	Screw M12x30 8.8 Zn	Schraube M12x30 8.8 Zn	2
39	150275400	Nut VM M10	Mutter VM M10	2
40	000221307	Nut M10	Mutter M10	1
41	150040208	Nut M16	Mutter M16	3
42	000228300	Washer B10	Scheibe B10	1
43	000228701	Washer B16	Scheibe B16	1
44	000240509	Cotter 5x63	Splinte 5x63	1
45	000239904	Cotter 5x32	Splinte 5x32	1
46	000239101	Cotter 4x32	Splinte 4x32	4
47	000238004	Circlip 60	Gimerungsring 60	1
48	000235007	Pin 10x40	Spannhülse10x40	1
49	150116305	Pin 8x30	Spannhülse 8x30	1
50	152237500-800.06.057.0	Washer 25,2/33-1,5	Scheibe 25,2/33-1,5	1
51	000240402	Cotter 5x50	Splinte 5x50	1
52	150037800	Reduction unit	Reduktor	1
53	000252906	Washer A22x27 Cu	Scheibe A22x27 Cu	1
54	150108403	Clamp AMD M22x1,5	Klemme AMD M22x1,5	1
55	150385504	TubeV1NP8x3150A10A20	RohrV1 NP8x3150 A10A20	1
56	151034615-511.05.010.1	Cover	Deckel	1
57	152448613-516.05.051.1	Bolt	Bolzen	1
58	154005604-547.05.017.0	Bar	Welle	1
59	151034615-511.05.010.1	Cover	Deckel	1
60	154195105-TN 01	Washer 16,5/29-1,25	Scheibe 16,5/29-1,25	2
61	152926213-516.05.054.1	Plastic string	Seil kpl.	1
62	151939503-338.00.008.0	Spring clip	Sicherungsstecker	1

A = ROTO 175 D, 215 D, ROTO 180 DS, ROTO 220 DS

B = ROTO 255 D, 295 D

Bild A

Fig A

Bild A  
Fig. A

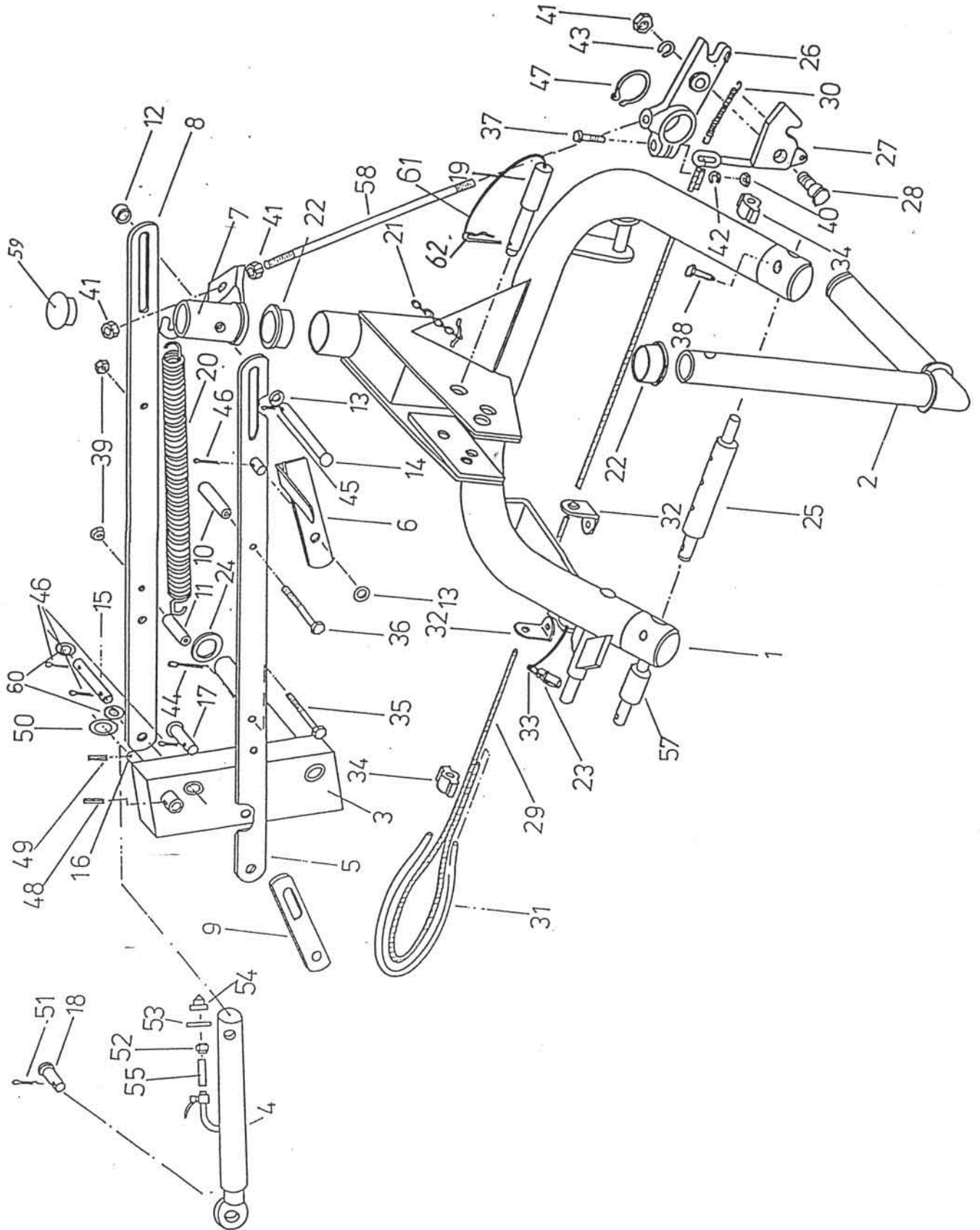

No. on the figure Nummer anzeichn.	Catalogue no. Katalog nummer	Description	Benennung	Quantity Stück
1	153844503-547.03.001.0	Disc welded	Scheibe schw.	A2,B3,C4,D5
2	153844709-547.03.003.0	Disc welded	Scheibe schw.	A2,B2,C2,D2
3	154155906-548.03.018.0	Flange right	Flansche recht	A1,B1,C2,D2
4	154156004-548.03.021.0	Flange left	Flansche links	A1,B2,C2,D3
5	153845512-547.03.024.1	Bearing Housing	Lagergehäuse schw.	A4,B5,C6,D7
6	153886111-547.03.039.1	Gear 29/4	Zahnrad 29/4	A4,B5,C6,D7
7	153845904-547.03.028.0	Gear 34/4 cpl.	Zahnrad 34/4 cpl.	A6,B6,C10, D10
8	153846012-547.03.029.1	Gear 34/4	Zahnrad 34/4	A6,B6,C10,D10
9	152148303-520.01.045.0	Protection wire	Sicherungsdraht	A18,B18,C30,D30
10	153846208-547.03.031.0	Shaft 1	Welle schw.	A1,B1,C1,D1
12	153846815-547.03.037.1	Shaft 2	Welle 2 schw.	A1,B1,C1,D1
14	153847500-547.03.040.0	Housing	Troggehäuse schw.	C1
14	153936405-549.03.040.0	Housing	Troggehäuse schw.	A1
14	153938726-548.03.040.2	Housing	Troggehäuse schw.	B1
14	153940624-550.03.040.2	Housing	Troggehäuse schw.	D1
15	153847804-547.03.043.0	Cover	Trogdeckel schw.	C1
15	153936600-549.03.043.0	Cover	Trogdeckel schw.	A1
15	153938922-548.03.043.2	Cover	Trogdeckel schw.	B1
15	153940820-550.03.043.2	Cover	Trogdeckel schw.	D1
16	153848108-547.03.046.0	Neck	Scharnier schw.	A1,B1,C1,D1
17	153848402-547.03.049.0	Neck	Scharnier schw.	A1,B1,C1,D1
18	153848607-547.03.068.0	Cover	Deckel	A2,B2,C2,D2
19	153848509-547.03.066.0	Tube	Rohr	A2,B2,C2,D2
20	153860101-547.03.081.0	Sleeve	Büchse	A6,B9,C10,D13
21	154008601-553.03.112.0	Band 2	Band 2	A3,B4,C5,D6
22	154009405-553.03.105.0	Slider	Schteberlager recht schw.	A1,B1,C1,D1
24	154055809-553.03.102.0	Band	Band	A1,B1,C1,D1
25	153860600-547.03.088.0	Screw 5	Schraube 5	A16,B20,C24,D28
26	153860708-547.03.089.0	Screw 7 M10x25	Schraube 7 M10x25	A16,B21,C22,D27
27	153860806-547.03.089.0	Screw M10x35	Schraube 7 M10x35	A12,B15,C18,D21
28	153860904-547.03.089.0	Screw 7 M10x40	Schraube 7 M10x40	A6,B9,C10,D13
29	154152703-548.03.027.0	Screw	Schraube	A2,B3,C3,D4
30	153171419-534.01.010.1	Knife right	Messer recht	A4,B4,C6,D6,E6,F9
31	154005516-547.03.099.1	Screw knife	Schraube messer	A8,B10,C12,D14,E12,F18
32	153171311-534.01.008.1	Knife left	Messer links	A4,B6,C6,D8,E6,F9
33	151159506-166.813	Washer 35,2/46,1	Scheibe 35,2/46,1	A6,B9,C10,D13
34	151014208-TN 01	Washer 30,2/38-1	Scheibe 30,2/38-1	A2,B2,C2,D2
36	000243115	Bearing KR 6206 2RS	Lager KR 6206 2RS	A2,B2,C2,D2
37	159165414	Bearing KR 6307 2RS	Lager KR 6307 2 RS	A10,B12,C14,D16
39	154225001-TN 01	Washer 35,2/46-2,7	Scheibe 35,2/46-2,7	A4,B5,C6,D7
41	150158705	Bearing 6207-2 RSN	Lager 6207-2 RSN	A6,B9,C10,D13
42	000236300	Circlip N62	Gimerungsring 62	A2,B2,C2,D2
43	150383506	Circlip 30x2	Gimerungsring 30x2	A2,B2,C2,D2
44	150048709	Circlip 80	Gimerungsring 80	A4,B5,C6,D7
46	153912207-547.03.091.0	Cover	Deckel schw.	A2,B3,C4,D5
47	154009307-553.03.104.0	Slider	Schieber	A1,B1,C1,D1
48	154152400-548.03.027.0	Screw	Schraube	A2,B2,C3,D3
49	000210701	Screw M10x30 8.8 Zn	Schraube M10x30 8.8 Zn	A1,B2,C2,D3
50	150393407	Screw M10x30 8.8 Zn	Schraube M10x30 8.8 Zn	A1,B1,C2,D2
51	150084009	Nut M10	Mutter M10	A38,B50,C62,D74,E12,F18
52	159444504	Screw M12x20	Schraube M12x20	A8,B12,C16,D20
53	000210300	Screw M10x25	Schraube M10x25	A8,B8,C8,D8
54	154009209-553.03.083.0	Slider	Schieber schw.	A2,B3,C4,D5
55	000221307	Nut M10 8 Zn	Mutter M10 8 Zn	A34,B37,D30,C53
56	000228408	Washer B10 Zn	Scheibe B10 Zn	A46,B59,C62,D75
57	000228603	Washer B12 Zn	Scheibe B12 Zn	A8,B12,C16,D20
58	000224206	Washer A10	Scheibe A10	A8,B8,C8,D8
60	153938500-548.03.029.0	Gear cpl.	Zahnrad cpl.	B3,D3
61	154035608-547.15.001.0	Disc welded	Scheibe schw.	E2,F2
62	154035804-547.15.003.0	Disc welded	Scheibe schw.	E2,F4
63	150275400	Nut VM10	Mutter VM10	A6,B9,C10,D13
64	153938500-548.03.029.0	Gear 25/4	Zahnrad 25/4	B3,D3
74	150230306	Screw M18x1,5 /5.8/	Schraube M18x1,5 /5.8/	C1,D1

A = ROTO 175 D

B = ROTO 215 D

C = ROTO 255 D

D = ROTO 295 D

E = ROTO 170 D ZDA

F = ROTO 260 D ZDA

Bild B Fig. B

Type Typ	Grease type Fett	Quantity Menge
ROTO 175 D	FUCHS RENOLIT-CL (VISKOMA R-00) 150004907	1,6 L
ROTO 215 D	FUCHS RENOLIT-CL (VISKOMA R-00) 150004907	2,1 L
ROTO 255 D	FUCHS RENOLIT-CL (VISKOMA R-00) 150004907	2,5 L
ROTO 295 D	FUCHS RENOLIT-CL (VISKOMA R-00) 150004907	3,1 L
ROTO 170 D (ZDA)	FUCHS RENOLIT-CL (VISKOMA R-00) 150004907	1,6 L
ROTO 260 D (ZDA)	FUCHS RENOLIT-CL (VISKOMA R-00) 150004907	2,5 L

Bild B  
Fig. B



Bild C

Fig. C

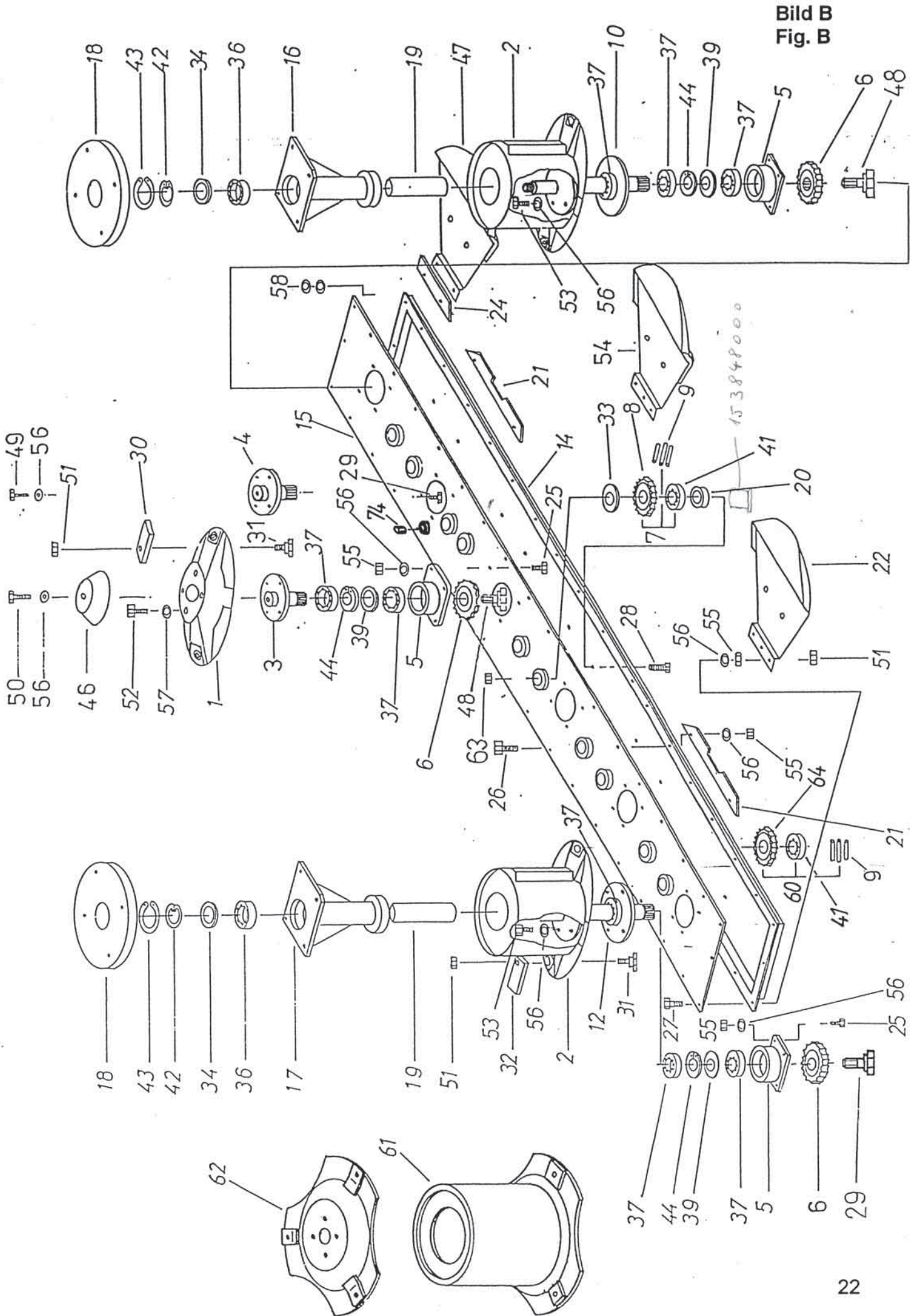
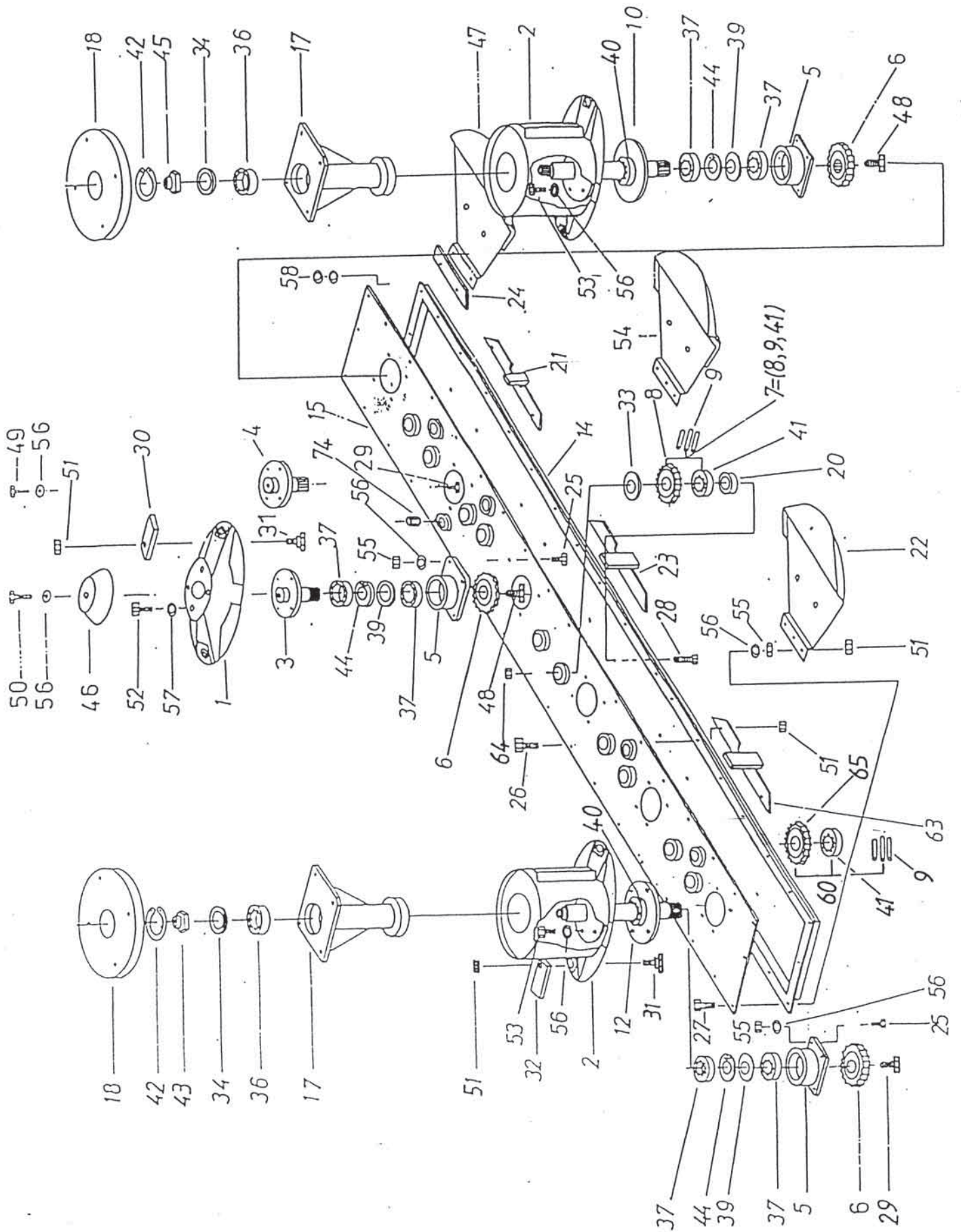

No. on the figure Numer anzeichn.	Catalogue no. Katalog nummer	Description	Benennung	Quantity Stueck	
1	153844503	547.03.001.0	Disc	Scheibe schw.	C2,D3
2	153844709	547.03.003.0	Disc	Scheibe schw.	C2,D2
3	154155906	548.03.018.0	Flange right	Flansche links	C1,D1
4	154156004	548.03.021.0	Flange left	Flansche rechts	C1,D2
5	154007808	553.03.024.0	Bearing housing	Lagergehäuse schw.	C4,D5
6	154007309	553.03.039.0	Gear 3-25/4	Zahnrad 3-25/4 gehärtet	C4,D5
7	154054203	553.03.011.0	Gear 3-27/4 cpl.	Zahnrad 3-27/4 gehärtet	C2,D2
8	154007407	553.03.029.0	Gear 3-27/4	Zahnrad 3-27/4 gehärtet	C2,D2
9	152148303	520.01.045.0	Wire safety	Sicherungsdraht	C42,D50
10	154159500	557.03.031.0	Shaft 1	Welle 1 schw.	C1,D1
12	154159706	557.03.037.0	Shaft 2	Welle 2 schw.	C1,D1
14	154023407	556.03.040.0	Housing	Troggehäuse schw.	C1
14	154008004	554.03.040.0	Housing	Troggehäuse schw.	D1
15	154023504	556.03.043.0	Trough cover	Trogdeckel schw.	C1
15	154008200	554.03.043.0	Trough cover	Trogdeckel schw.	D1
17	154160106	557.03.046.0	Neck	Angel schw.	C2,D2
18	153848607	547.03.068.0	Cover	Deckel	C2,D2
20	153860101	547.03.081.0	Sleeve 4-35/42,4-9	Buchse 43-5/42,4-9	C8,D11
21	154008503	553.03.111.0	Band 1	Band 1 schw.	C2,D3
22	154009405	553.03.105.0	Slider right	Schieber rechts schw.	C1,D1
23	154008601	553.03.112.0	Band 2	Band 2 schw.	C1,D1
24	154106808	553.03.120.0	Band left	Band links schw.	C1,D1
25	153860600	547.03.088.0	Screw 5-M10x25	Schraube 5-M10x25 gehärtet	C16,D20
26	153860708	547.03.089.0	Screw 7-M10x25 Zn	Schraube 7-M10x25 Zn	C12,D15
27	153860806	547.03.089.0	Screw 7-M10x35 Zn	Schraube 7-M10x35 Zn	C12,D15
28	153860904	547.03.089.0	Screw 7-M10x40 Zn	Schraube 7-M10x40 Zn	C8,D11
29	154152703	548.03.027.0	Screw M14left	Schraube M14 links	C1,D2
30	153171419	534.01.010.1	Knife right	Messer rechts	C2,D2
31	154005516	547.03.099.1	Knife screw	Messerschraube-Schwarze	C8,D10
32	153171311	534.01.008.1	Knife left	Messer links	C2,D3
33	151159506	166.813	Washer 35.2/46-1	Scheibe 35,2/46-1 gehärtet	C8,D11
36	150406000	DIN 625	Bearing KR6207-2RS	Lager KR6207-2RS	C2,D2
37	159165414	DIN 625	Bearing KR6307-2RS C3	Lager KR6307-2RS C3	C4,D10
39	154225001	557.03.025.0	Washer 35.2/52-2,7	Scheibe 35,2/52-2,7 gehärtet	C4,D5
40	150429502	DIN 625	Bearing KR6209-2RS C3	Lager KR6209-2RS C3	C2,D2
41	150158705	DIN 625	Bearing KR6207-2RSN	Lager KR6207-2RSN	C8,D11
42	000236505		Circlip N 72	Sicherungsring N 72	C2,D2
43	154159902	557.03.044.0	Nut 1-M33x1,5 right	Mutter 1-M33x1,5 rechts	C1,D1
44	150048709		Circlip N 80	Sicherungsring N 80	C4,D5
45	154160008	557.03.044.0	Nut 1-M33x1,5 left	Mutter 1-M33x1,5 links	C1,D1
46	153912207	547.03.091.0	Cover	Deckel schw	C2,D3
47	154009307	553.03.104.0	Slider left	Schieber links schw.	C1,D1
48	154152400	548.03.027.0	Screw M14right	Schraube M14 rechts	C3,D3
49	000210701		Screw M10x30/8.8/Zn	Schraube M10x30/8.8/Zn	C2,D3
50	150393407		Screw M10x30 left/8.8/Zn	Schraube M10x30 links/8.8/Zn	C2,D2
51	150084009	DIN 985	Nut M10/8/ Cd	Mutter M10 /8/ Cd	C2,D2
52	159444504		Screw M12x20/8.8/Zn	Schraube M12x20 /8.8/ Zn	C8,D12
53	000210300		Screw M10x25/8.8/Zn	Schraube M10x25 /8.8/ Zn	C8,D8
54	154009209	553.03.083.0	Slider	Schieber schw.	C2,D3
55	000221307		Nut M10/8/ Zn	Mutter M10 /8/ Zn	C42,D52
56	000228408		Washer B10 Zn	Federscheibe B10 Zn	C47,D67
57	000228603		Washer B12 Zn	Federscheibe B12 Zn	C8,D12
58	000224509		Washer A12	Scheibe A12	C8,D8
60	154054203	553.03.011.0	Gear 3-27/4	Zahnrad 3-27/4 Kpl.	C6,D9
63	154106906	553.03.119.0	Band 11	Band 11schw.	C1,D1
64	150275400	DIN 980	Nut VM10 /8/ Zn	Mutter VM10 /8/ Zn	C8,D11
65	154007407	553.03.029.0	Gear 3 27/4	Zahnrad 3 27/4	C6,D9
74	150230306	DIN 906	Screw M18x1,5/5.8/	Schraube M18x1,5 /5.8/	C1,D1

C = ROTO 180 DS  
D = ROTO 220 DS

Bild C

Fig. C

No. on the figure Numer anzeichn.	Catalogue no. Katalog nummer	Description	Benennung	Quantity Stück
1	153849009-547.03.051.0	Gear-box housing	Sntriebsgehäuse	1
2	153849107-547.03.052.0	Pinion 30/4	Kegelrad 30/4	1
3	153849205-547.03.053.0	Pinion 16/4	Kegelrad 16/4	1
4	153849313-547.03.054.1	Flange 1	Flansche 1 schw.K	1
5	153849518-547.03.057.1	Flange 2	Flansche 2 schw.	1
6	153849704-547.03.059.0	Shaft 3	Welle 3	1
7	153849812-547.03.060.1	Shaft	Welle schw.	1
8	152170108-520.02.017.0	Pulley	Keilremenscheibe	1
9	151012406-455.05.055.0	Elastic ring A30	Elastikring A30	1
10	000230707	Key A8x7x45	Dübel A8x7x45	2
11	159908102	Circlip N85	Gimmerungsring N85	2
12	150008306	Bearing KR 6209	Lager KR 6209	1
14	000237906	Circlip 45	Gimmerungsring 45	1
15	000237407	Circlip 25	Gimmerungsring 25	1
16	151012905-TN 01	Washer 25,2/33	Scheiben 25,2/33	1
17	000236300	Circlip N62	Gimmerungsring N62	1
18	000242919	Bearing KR 6305 2 RS	Lager KR 6305 2 RS	1
19	150401319	Key B8x7x28	Dübel B8x7x28	1
20	152497809-453.01.012.0	Washer 45/56-0,2	Scheibe 45/56-0,2	2
21	152497907-453.01.012.0	Washer 45/56-0,3	Scheibe 45/56-0,3	2
22	150307108-P166.830	Washer 45/54-1	Scheibe 45/54-1	2
23	150004505	Bearing KR 4206 N625	Lager KR 4206 N625	1
24	150004408-SIMRIT	Oil seal A45x62x7N 3760	Dichtungsring A45x62x7N 3760	3
25	151002300-510.01.019.0	Washer	Sicherungsscheibe	1
26	151002408-455.05.051.0	Nut M30x1,5	Mutter M30x1,5	1
27	000210202	Screw M10x25	Schraube M10x25	6
28	153850201-547.03.064.0	Protection plate 1	Sicherungsblech 1	2
29	153850309-547.03.065.0	Protection plate 2	Sicherungsblech 2	2
30	150230306	Screw locking M18x1,5	Sicherungsschraube M18x1,5	1
31	153850103-547.03.063.0	Sleeve 1	Büchse 1	1
35	153850407-547.03.070.0	Holder welded	Träger	C1
35	153936806-549.03.070.0	Holder welded	Träger	A1
35	153939108-548.03.070.0	Holder welded	Träger	B1
35	153941006-550.03.070.0	Holder welded	Träger	D1
36	153848705-547.03.069.0	Plate	Blechscheibe	3
37	150386004	Washer 12 Zn	Scheibe 12 Zn	2
38	000248805	Screw M10x35 8.8 Zn	Schraube M10x35 8.8 Zn	6
39	153989303-547.03.110.0	Screw M10x35 8.8 Zn	Schraube M10x35 8.8 Zn	2
40	150386102	Screw M10x25 8.8 Zn	Schraube M10x25 8.8 Zn	4
41	150389706	Screw M12x185 10.9 Zn	Schraube M12x185 10.9 Zn	3
42	150393602	Nut VM12 8 Zn	Mutter VM12 8 Zn	3

**A = ROTO 175 D, ROTO 180 DS**  
**B = ROTO 215 D, ROTO 220 DS**  
**C = ROTO 255 D**  
**D = ROTO 295 D**

**Bild D Fig D**

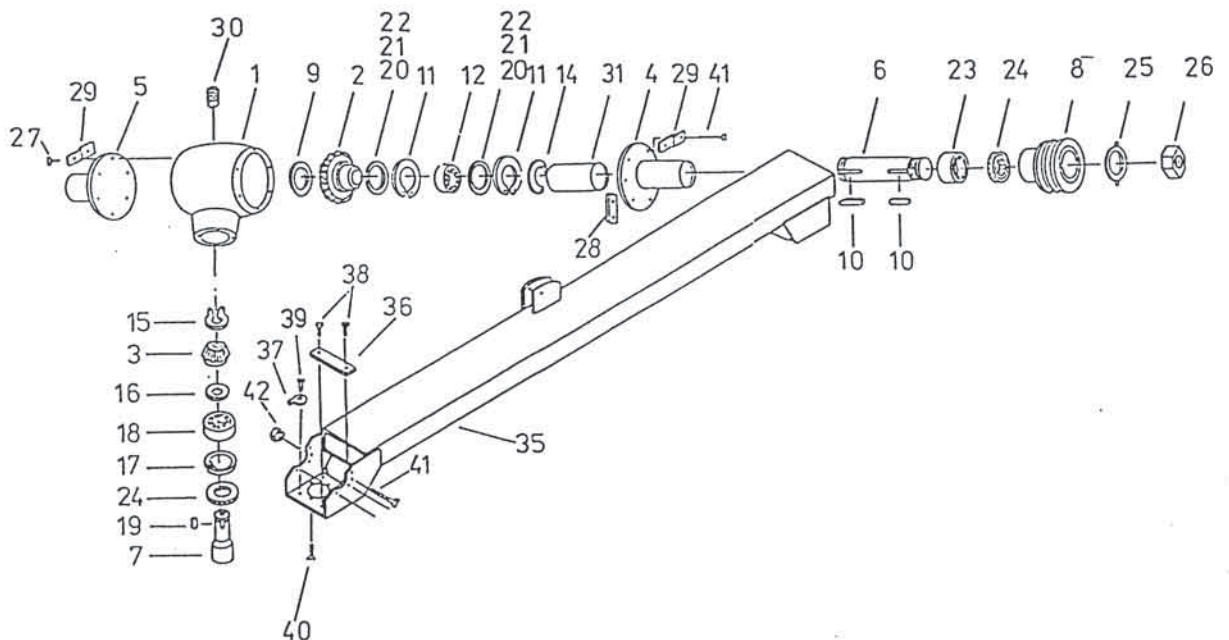



No. on the figure Numer anzeichn.	Catalogue no. Katalog nummer	Description	Benennung	Quantity Stück
1	151007001-510.02.044.0	Neck	Schnier	2
2	153839500-547.02.001.0	Holder	Träger schw.	1
3	153841007-547.02.021.0	Protection	Sicherung schw.	1
4	153840507-547.02.051.0	Inner protection	Innensicherung	1
5	151007207-510.02.045.0	Sleeve	Büchse	1
7	151007608-510.02.052.0	Bolt 1	Bolzen 1	1
8	154005409-547.02.027.0	Safety clamp	Sicherung	1
9	151726403-513.02.029.0	Protector	Sicherungen	1
10	151007403-510.02.047.0	Protection plate	Sicherungsblech	2
11	153245714-342.00.015.1	String cpl.	Seile kpl.	1
12	154547306-547.02.150.0	Belt protection	Riemenschutz	1
13	153926201-547.02.006.0	Support leg	Stütz fuss	1
14	153240102-TN 01	Washer 15/50-4 Zn	Scheibe 15/50-04 Zn	1
15	150392809	Screw M14x215 8.8	Schraube M14x215 8.8	1
16	150104309	Screw M16x30 8.8 Zn	Schraube M16x30 8.8 Zn	2
17	000224304-	Washer A10	Scheibe A10	4
18	150392701	Screw M16x65 12.9 Zn	Sekskantschraube M16x65 12.9 Zn	1
19	000250908	Nut M14 5 Cd	Mutter M14 5 Cd	1
20	000210300	Screw M10x25 8.8 Zn	Schraube M10x25 8.8 Zn	4
21	000228408	Washer B10 Zn	Scheibe B10 Zn	4
22	000239101	Cotter 4x32	Splint 4 x32	1
23	000240304	Cotter 5x50	Splint 5x50	1
24	000246503	Lubricator	Schmirnippel	5
25	151007922-510.02.054.2	Cover	Deckel	1
26	150392603-APRAM	Safety pin	Sicherungsstift	1
27	154005409-547.02.027.0	Spring	Feder	1
28	000252808	Washer A6x10 Cu	Scheibe	2
29	153926818-547.02.024.1	Protector	Sicherung kpl.	1
30	153926103-547.02.030.0	Band	Band	1
31	000253807	Screw M16x40 8.8 Zn	Schraube M16x40 8.8 Zn	1
32	151001800-510.01.015.0	Clamp	Schelle	1
33	150000509	Screw M6x55	Schraube M6x55	1
34	000250506-DIN 985	Nut M6	Mutter M6	1

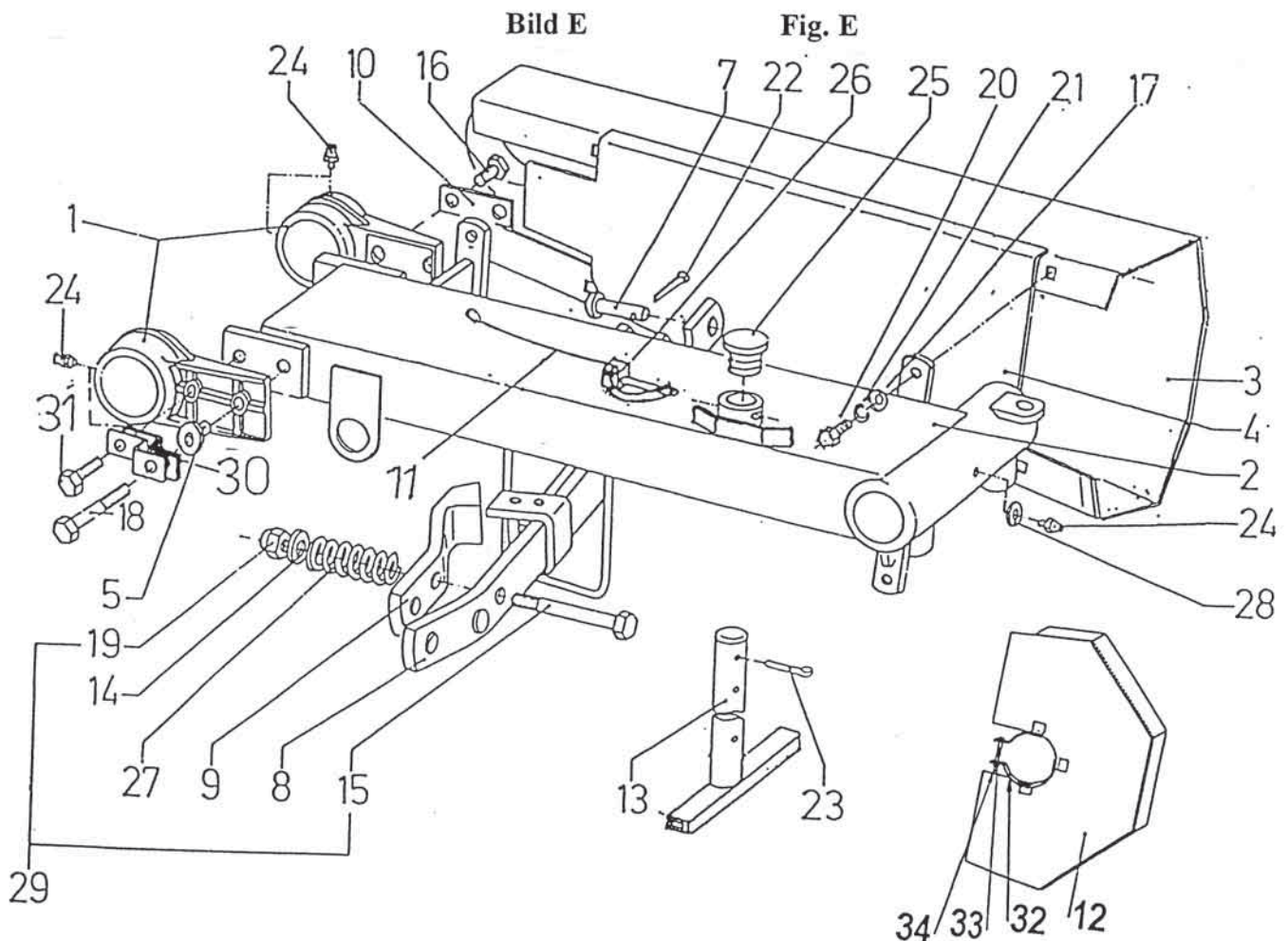

No. on the figure Numer anzeichn.	Catalogue no. Katalog nummer	Description	Benennung	Quantity Stück
1	152162705-520.03.003.0	Pulley	Keilrimmscheibe	1
2	152005403-516.01.001.0	Bearing housing	Lager gehäuse	1
3	154045107-547.01.010.0	Tensioner	Spanner	1
4	153473903-455.05.051.0	Nut M30x1,5	Mutter M30x1,5	1
5	151002300-510.01.019.0	Washer	Sicherungsscheibe	1
6	152005628-516.01.004.2	Bolt	Bolzen	1
8	151001506-510.01.013.0	Support	Lehne	1
9	151002006-510.01.018.0	Cover	Deckel	1
10	153839814-547.01.008.1	Shaft	Antriebswelle	1
11	151001908-510.01.017.0	Distance tube	Distanzrohr	1
12	151002202-TN01	Washer	Scheibe	1
13	150040208	Nut M16	Mutter M16	2
14	000224803	Washer A16	Scheibe A16	1
15	000239101	Cotter 4x32	Splint 4x32	1
16	000254904	Screw M6x45 8.8 Zn	Schraube M6x45 8.8 Zn	1
17	150406000	Bearing 6207 2 RS	Lager 6207 2 RS	2
18	000256608	Key A 10x8x50	Passfeder A 10x8x50	1
19	153996901-516.01.025.0	P.T.O. Shaft protection	Gelenkwellesicherung	1
20	150390008	Vee belt SPBx2950	Keilrimmen	4
21	151002104-455.04.043.0	Elastic ring A35	Elastikring A35	1
22	153742007-546.02.065.0	Spring 1	Feder 1	1
23	000250506	Nut M6	Mutter M6	1
24	000225900	Washer C10	Scheibe C10	2
26	150106806	Screw M10x20 8.8 Zn	Schraube M10x20 8.8 Zn	2
27	000221307	Nut M10 8 Zn	Mutter M10 8 Zn	2
28	000225303	Washer 10	Scheibe 10	2
30	152364907-520.04.111.0	Sleeve	Büchse	1

Bild F

Fig F



Bild G  
Fig. G



No. on the figure Numer anzeichn.	Catalogue no. Katalog nummer	Description	Benennung	Quantity Stück
1	153844406-547.00.046.0	Bolt 4	Bolzen 4	A2,B2,C3,D3
2	153937110-549.00.015.1	Front cover plate	Blech vorne schw.	A1,B1
2	153841506-547.00.015.0	Front cover plate	Blech vorne schw.	C1
2	153940301-550.00.015.0	Front cover plate	Blech vorne schw.	D1
3	153841908-547.00.019.0	Side cover plate	Blech seiten	A1,B1,C1,D1
4	153842202-547.00.022.0	Cover plate	Blech schw.	A1,B1,C1,
4	153939607-548.00.020.0	Cover plate	Blech schw.	D1
5	153937404-549.00.025.0	Cover plate	Blech schw.	A1
5	154053204-548.00.025.0	Cover plate	Blech schw.	C1,D1
5	154053204-548.00.025.0	Cover plate	Blech schw.	B1
6	154203702-549.00.030.0	Link 1	Verbindung schw 1	A1,B1
6	153842809-547.00.030.0	Link 1	Verbindung schw. 1	C1,D1
7	153843602-547.00.038.0	Link 5	Verbindung schw. 5	A1,B1,C1,D1
8	153937707-549.00.044.0	Band 2	Band 2	A2
8	153844200-547.00.044.0	Band 2	Band 2	C2,D2
8	154108502-548.00.044.0	Link 6	Verbindung 6	B2
9	153842907-547.00.031.0	Link 2	Verbindung 2	A1,B2,C2,D2
10	153843700-547.00.039.0	Link 6	Verbindung 6	A1,B2,C2,D2
11	153843407-547.00.036.0	Link 3	Verbindung 3	A1,B1,C1,D2
12	153843504-547.00.037.0	Link 4	Verbindung 4	A1,B1,C1,D1
13	153844102-547.00.043.0	Support 3	Stütze 3	A1,B1,C1,D1
14	153130007-P 499.045	Curtain left	Sicherungsleine links	A1,B1,C1,D1
15	153953608-547.00.011.0	Curtain front	Vorhang vorne	A1
15	153953706-547.00.011.0	Curtain front	Vorhang vorne	B1
15	153841203-547.00.011.0	Curtain front	Vorhang vorne	C1
15	153953804-547.00.011.0	Curtain front	Vorhang vorne	D1
16	153841301-547.00.012.0	Curtain side	Vorhang seitlich	A1,B1,C1
16	153954206-547.00.012.0	Curtain side	Vorhang seitlich	D1
17	153955205-549.50.014.0	Curtain rear	Vorhang hinten	A1
17	154053008-548.50.014.0	Curtain rear	Vorhang hinten	B1
17	153841409-547.00.014.0	Curtain rear	Vorhang hinten	C1
17	153956909-547.00.014.0	Curtain rear	Vorhang hinten	D1
14	153934103-547.00.010.0	Curtain left	Sicherungsleine links	A1,B1,C1,D1
15	153953902-547.00.011.1	Curtain front	Vorhang vorne	A1
15	153954000-547.00.011.1	Curtain front	Vorhang vorne	B1
15	153841213-547.00.011.1	Curtain front	Vorhang vorne	C1
15	153954108-547.00.011.0	Curtain front	Vorhang vorne	D1
16	153841311-547.00.012.1	Curtain side	Vorhang seitlich	A1,B1,C1
16	153954304-547.00.012.1	Curtain side	Vorhang seitlich	D1
17	153956106-549.54.014.1	Curtain rear	Vorhang hinten	A1
17	154053106-548.54.014.0	Curtain rear	Vorhang hinten	B1
17	153841419-547.00.014.1	Curtain rear	Vorhang hinten	C1
17	153957007-547.00.014.1	Curtain rear	Vorhang hinten	D1
18	150300301	Screw A 4,2x13	Schraube A 4,2x13	A8,B8,B8,D8
19	150143008	Screw M8x25	Schraube M8x25	A10,B14,C12,D16
20	150319809	Screw M8x35	Schraube M8x35	A9,B9,C11,D11
21	000208509	Screw M8x15	Schraube M8x15	A3,B3,C3,D3
22	150007003	Screw M10x70	Schraube M10x70	A2,B3,C3,D3
23	000210701	Screw M10x30	Schraube M10x30	A4,B4,C4,D4
24	150386308	Screw M10x25	Schraube M10x25	A1,B1,C1,D1
25	150386200	Screw M10x95 8.8 Zn	Schraube M10x95 8.8 Zn	A1,B2,C2,D2
26	150320405	Screw M10x100	Schraube M10x100	A1,B2,C2,D4
27	150275302	Nut V M8	Mutter V M8	A22,B26,C26,D30
28	000250702	Nut M10 5 Cd	Mutter M10 5 Cd	A2,B3,C3,D3
29	000221307	Nut M10	Mutter M10	A6,B9,C9,D11
30	151159908-TN 01	Washer	Scheibe	A3,B3,C3,D3
31	000228408-250.00.002.0	Washer B10	Scheibe B10	A9,B9,C9,D11
32	151322900	Wire safety clamp	Sicherungsdraht	A2,B3,C3,D2
33	153932800-547.00.059.0	Eye	Ohr	A4,B4,C4,D4
34	153937805-549.00.022.0	Plate	Blech schw.	A1,C1
34	153939705-548.00.022.0	Plate	Blech schw.	B1,D1
35	153885905-547.00.050.0	Holder left	Träger links	C1,D1
36	153886307-547.00.062.0	Holder right	Träger recht	A1,B1,C1,D1
37	153886405-547.00.054.0	Plate left	Blach links	C1,D1
38	153886708-547.00.057.0	Plate right	Blach recht	A1,B1,C1,D1
39	151485002-590.05.228.0	Spring	Feder	A1,B1,C2,D2
40	000248805	Screw M12x35	Schraube M12x35	A2,B2,C4,D4
41	150388903	Screw M14x75	Schraube M14x75	A1,B1,C2,D2
42	000250908	Nut M14	Mutter M14	A1,B1,C2,D2
43	150160300	Nut M12	Mutter M12	A2,B2,C4,D4
44	000228603	Washer B12	Scheibe B12	A2,B2,C4,D4

A = ROTO 175 D, ROTO 180 DS  
B = ROTO 215 D, ROTO 220 DS  
C = ROTO 255 D  
D = ROTO 295 D

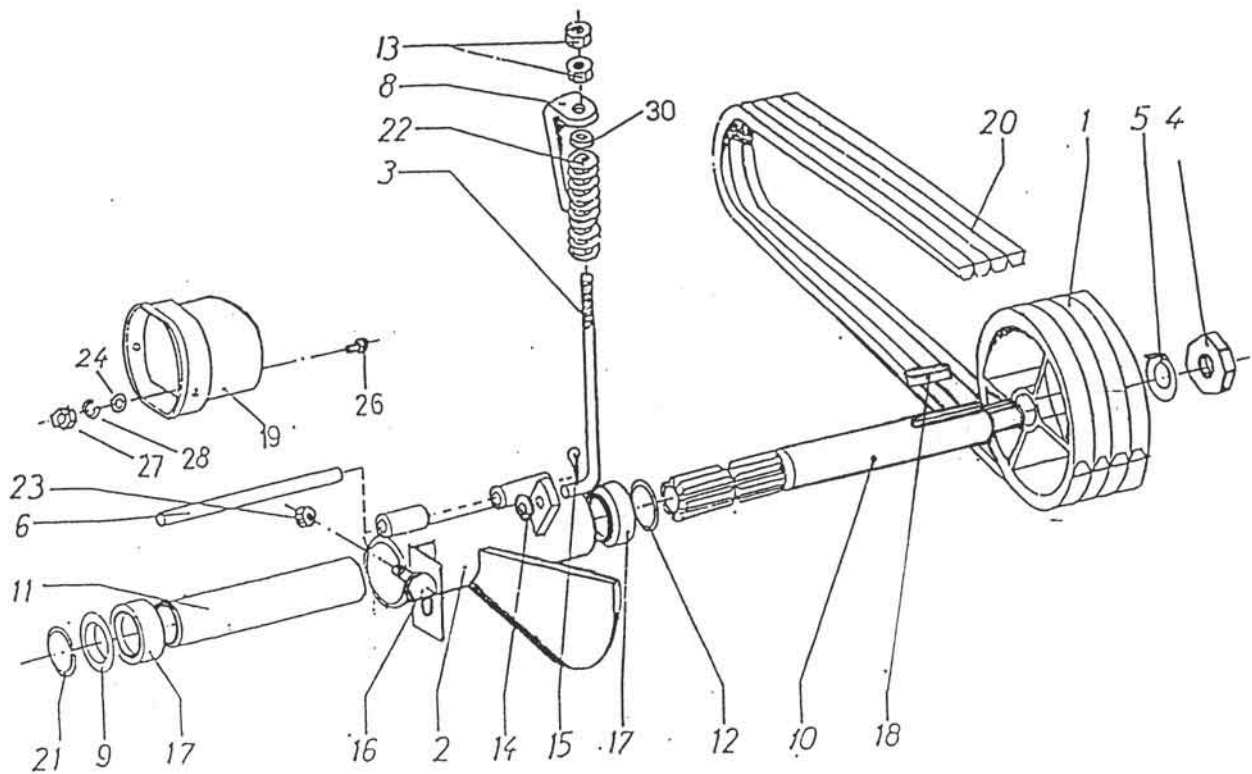
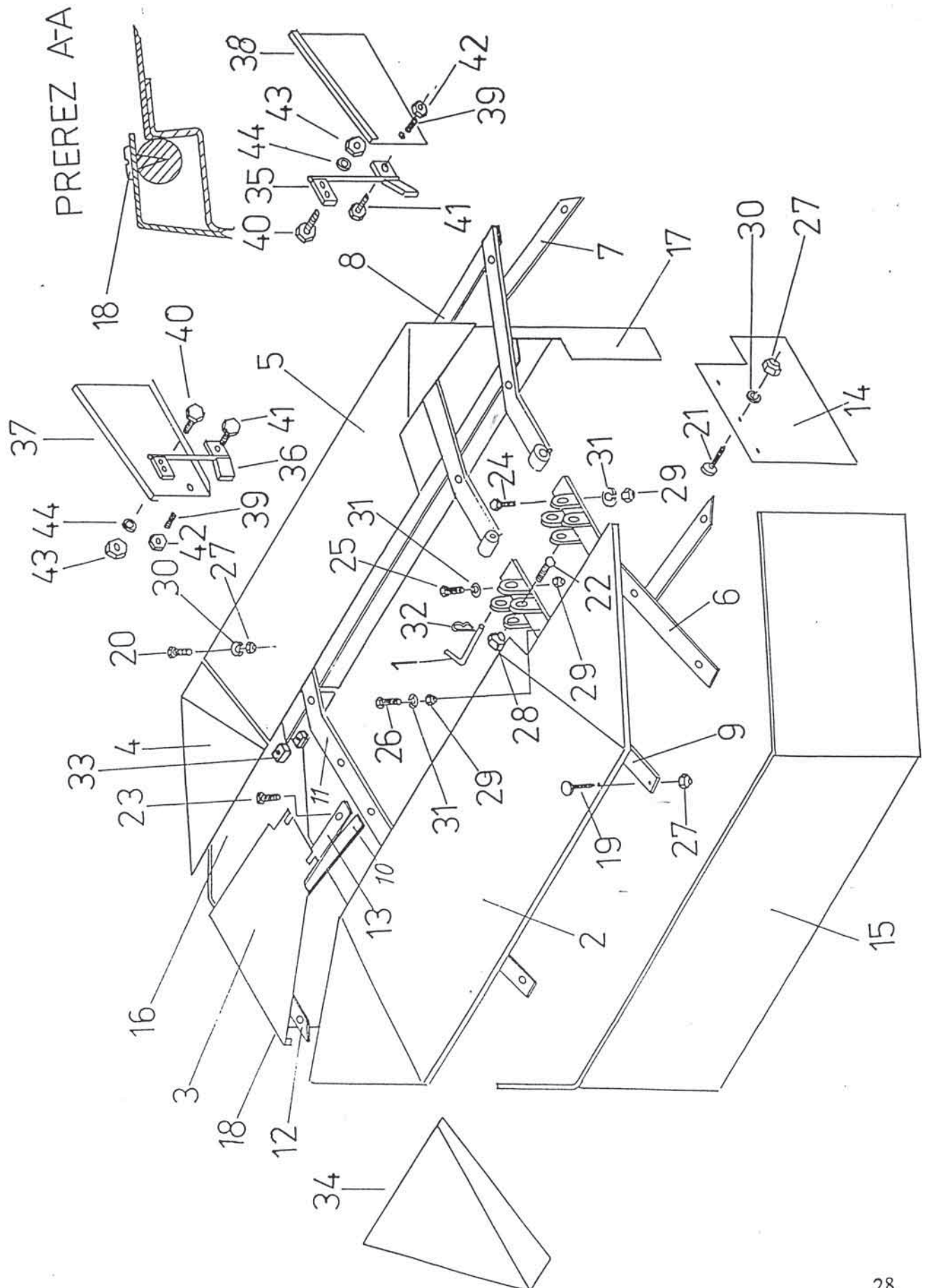
Bild G Fig. G

# BEDIENUNGS ANLEITUNG FÜR DIE MÄHWERKE MIT DEN CONDITIONER - AUFBEREITER

## TECHNISCHE DATEN :

	<b>ROTO 175 D</b>
Leistungsbedarf mit Aufb.	30 kW
Drehzahl des Aufbereiters	1000 min <sup>-1</sup>
Gewicht des Aufbereiters	92 kg
Gesamtgewicht mit Aufb.	467 kg
Zinkenform	Y
Gelenkwelle des Aufbereiters	ByPy-101-071-N-007-098

## TECHNICAL DATA

	<b>ROTO 215 D</b>	
	35 kW	Tractor power
	1000 min <sup>-1</sup>	Rotations
	118 kg	Weight of the conditioner
	518 kg	Weight of the mower&cond
	Y	Shape of the conditioning fingers
	ByPy-101-071-N-007-098	P.T.O Shaft for the conditioner

## MONTAGE UND DEMONTAGE DES AUFBEREITERS

- Abösen die Schrauben Pos. 25, 29 und 22, 29, Bild G und abnehmen hintere Schutzblech Pos. 5, Bild G.
- Durch die Ablösung von zwei Schrauben Pos. 40, 43, 44, Bild G abnehmen den Träger Pos. 35, 36, Bild G und damit den Schwadformer Pos. 37, 38, Bild G.
- Mit den Schrauben Pos. 15, 11, Bild H anschrauben den Träger Pos. 7, Bild H an oberen Träger Pos. 35, Bild D.
- Befestigen den Aufbereiter Pos. 1, Bild H an den Träger Pos. 7, Bild H, wie zeigt Bild H, Pos. 12, 13.
- Anschrauben den Aufbereiter an die Zwischenstrebe Pos. 9, Bild G mit den Schrauben Pos. 25, 29 und 22, 28, Bild G an oberen Träger Pos. 35, Bild D.
- Mutter, Pos.4, Bild F abschrauben, Aufbereiter-Getriebe Pos. 2, Bild H aufstecken, und Schrauben Pos. 38,39 auf der Welle Pos. 1, Bild K, welche die Welle, Pos. 10, Bild F fest umschließen, zuziehen.
- Mit den zwei Schrauben Pos. 10, 11, Bild H montieren einen Träger mit der Ohr Pos. 5, Bild G an den Hauptträger Pos. 2, Bild E.
- Einsetzen die Gelenkwelle Pos. 9, Bild H zwischen das Aufbereitergetriebe Pos. 2, Bild H und den Aufbereiter Pos. 1, Bild H.
- Demontage des Aufbereiters läuft durchweg in umgekehrten Bedeutung. Die Schutzblechen sollen montieren werden.
- Bei der Montage und Demontage des Aufbereiters müssen Sie besonders an mögliche Verletzungen denken.

## ASSEMBLY AND DISASSEMBLY OF THE CONDITIONER

- Unwind the screws pos.25,29 and 22,28, fig.G and take off the rear cover plate pos.5, fig G.
- Unwind 2 screws pos.40,43,44 fig.G, then remove the holders pos.35,36, fig G and take off the guidance pos.37,38, fig G.
- Tighten the holders pos.7, fig H to the upper holder pos.35, fig D by screws pos.15,11, fig H.
- Install the conditioner pos.1, fig H to the holders pos.7 (push into the groove on the holder) and screw down as shown on the fig.H pos.12,13.
- Tighten the conditioner onto the link 2 pos.9, fig G by screws pos.25,29 and 22,28 fig G onto the upper holder pos.35, fig.D.
- Remove the nut pos. 4, Fig. F, put the conditioner gear box pos. 2, Fig. H on the mower, and screw tight the screws pos. 38,39 on the shaft pos. 1 Fig. K, to clasp tight the shaft pos. 10, Fig. F.
- Mount the holder pos.6, fig H with the eye pos.5 fig G onto the main holder pos.2, fig E; Screw down by 2 screws pos 10,11 fig H.
- Put the P.T.O. Shaft pos.9, fig H between the conditioner gearbox pos 2, fig H and the conditioner pos.1, fig H.
- To disassemble the conditioner, do all the above steps in the reverse order of precedence. At the and you have to moment the protection cover plates.
- When assembling and disassembling the conditioner be careful to avoid injuries.

### ANSTELLUNG DES AUFBEREITERS

Aufbereiterintensivitet anstellen mit dem Händchen Bild 20, das die Klappenentfernung reguliert. Für kräftige Gras wird die Klappe mehr wie bei milder Gras entfernt.

### ADJUSTMENT OF THE CONDITIONER

The intensity of the conditioning is adjusted by the adjustment handle fig 20 by which you get the flap closer or more away from the top of the conditioning cylinder. The flap should be closer to the cylinder when mowing stronger grass, and more away when mowing weaker grass.

Bild 20

Fig 20

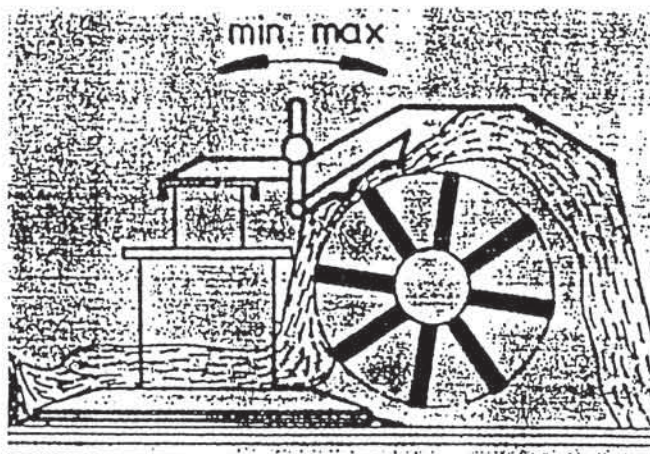

- Festigungsschraube an die Gelenkwellekupplung für die Antrieb des Aufbereiters muss man immer mit beschriebener Schraube wechseln werden., wann notwendig ist.

- The sheer bolt on the clutch of the P.T.O. Shaft for the drive of the conditioner should always be replaced by the prescribed original screw, when necessary.

No. on the figure Numer anzeichn.	Catalogue no. Katalog nummer	Benennung	Description	Quantity Stück
1	154059306-549.07.001.0	Aufbereiter	Conditioner	A1
1	154069705-548.07.001.0	Aufbereiter	Conditioner	B1
2	154064504-548.08.000.0	Getrige des Aufbereiters	Conditioner gearbox	1
3	151001614-510.01.014.1	Gelenkwellesicherung	P.T.O. Shaft protection	1
4	150134303	Schelle	Clamp	1
5	154064906-548.08.004.0	Ohr	Eye	1
6	154065004-548.08.005.0	Träger	Holder	1
7	154060401-549.07.009.0	Träger	Holder	2
9	150134205-Kardan 019.0	Gelenkwelle	P.T.O. Shaft	1
10	150046603	Schraube M12x110	Screw M12x110	2
11	150196004	Mutter M12	Nut M12	6
12	150367908	Mutter M16	Nut M16	2
13	152290504-TN 01	Unterlage 16,5/34-3	Washer 16,5/34-3	2
14	153955606-TN 08-04	Kleber SIP ROTO 175 D	Decal SIP ROTO 175 D	1A
14	153955401-TN 08-04	Kleber SIP ROTO 215 D	Decal SIP ROTO 215 D	1B
15	000248805	Schraube M12x35	Screw M12x35	4

A=ROTO 175 D  
B=ROTO 215 D

Bild H Fig H



Bild I  
Fig.1



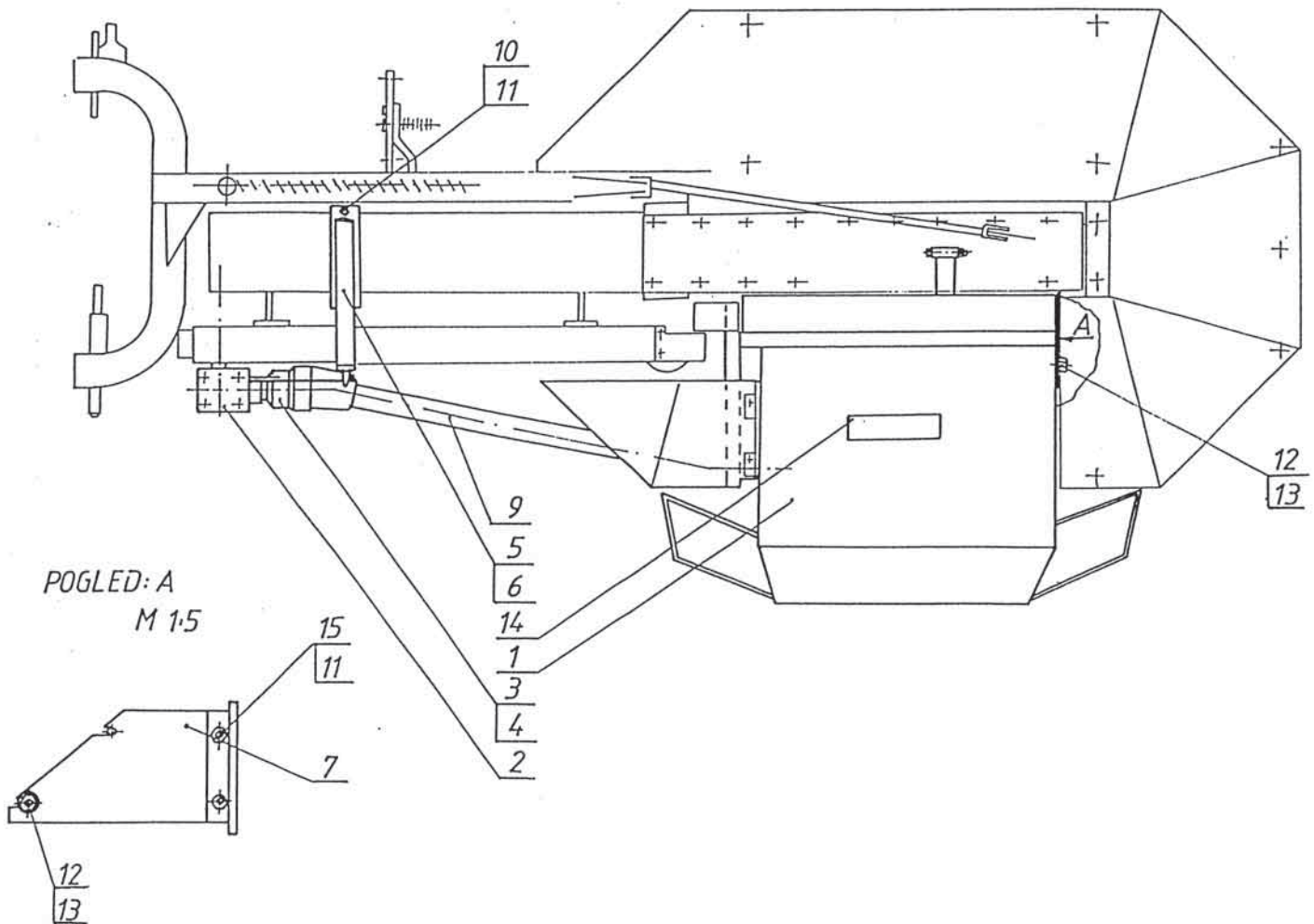
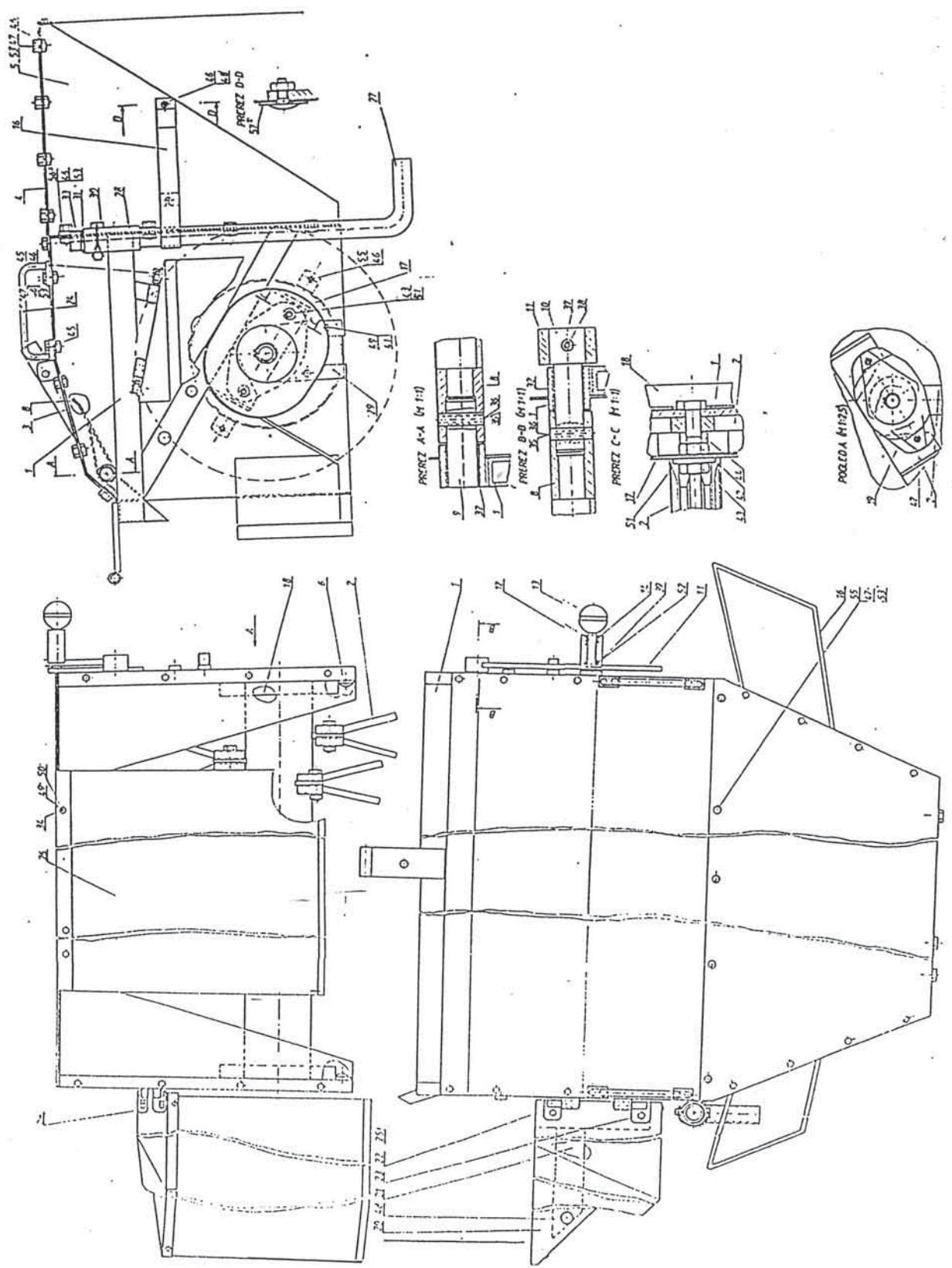

No. on the figure Numer anzeichn.	Catalogue no. Katalog nummer	Benennung	Description	Quantity Stück
1	154059404-549.07.002.0	Gestell schw.	Frame	A1
1	154069803-548.07.002.0	Gestell schw.	Frame	B1
2	154061106-549.07.020.0	Aufbereiterwalze	Conditioning cylinder	A1
2	154069901-548.07.020.0	Aufbereiterwalze	Conditioning cylinder	B1
3	154062203-549.07.040.0	Deckel	Cover	A1
3	154070506-548.07.040.0	Deckel	Cover	B1
4	154062301-549.07.041.0	Deckel-Formbildig	Cover	A1
4	154070604-548.07.041.0	Deckel-Formbildig	Cover	B1
5	154062409-549.07.042.0	Seitenblech links	Left side	A1
5	154070702-548.07.042.0	Seitenblech links	Left side	B1
6	154062506-549.07.042.0	Seitenblech rechts	Right side	A1
6	154070800-548.07.042.0	Seitenblech rechts	Right side	B1
8	154062604-549.07.050.0	Klappe schw.	Flap	A1
8	154070203-548.07.050.0	Klappe schw.	Flap	B1
9	154062908-549.07.054.0	Bolzen 4	Bolt 4	1
10	154063006-549.07.055.0	Bolzen 19	Bolt 19	1
11	151923404-515.07.041.0	Händchen schw.	Handle	1
12	151078700-260.11.003.0	Bolzen	Bolt	1
13	151078808-310.00.002.0	Kogel	Ball	1
14	151078602-215.11.006.0	Feder	Spring	1
16	154063104-549.07.060.0	Sutz schw.	Protection	2
17	154151704-549.07.036.0	Gelenkwellessicherung	P.T.O Shaft protection	1
18	154289807-557.07.026.0	Deckel schw.	Cover	2
19	154169508-549.07.095.0	Lagerschutz	Bearing protection	1
20	154063505-549.07.068.0	Blech schw.	Plate	1
21	154063809-549.07.071.0	Zwischenstrebe	Link	1
22	153697306-541.07.011.0	Schamir links schw	Neck	1
23	153697404-541.07.015.0	Schamir rechts schw.	Neck	1
24	154289004-557.07.030.0	Hebel	Handle	2
25	154064103-549.07.075.0	Vorhänge	Curtain	1
26	154064201-549.07.076.0	Aubereitervorhänge	Conditioner curtain	A1
26	154070908-548.07.076.0	Aufbereitervorhänge	Conditioner curtain	B1
27	154168607-549.07.090.0	Stutzfuss	Suport leg	1
28	154168705-549.07.091.0	Rohr schw.	Tube	1
29	154289905- 557.07.025.0	Blech 1	Plate 1	1
30	150392603	Spannstift	Safety pin	1
31	151007922-510.02.054.2	Deckel	Cover	1
32	150394406-Glacier	Buchse PM 2020 0X	Sleeve PM 2020 0X	2
33	000240304	Splinte 5x50	Cotter 5x50	1
34	000257108	Unterlage C6	Washer C6	5
35	000234008	Spannhülse 8x32	Pin 8x32	2
36	000232607	Spannhülse 5x32	Pin 5x32	2
37	000234204	Spannhülse 8x40	Pin 8x40	1
38	000232803	Spannhülse 5x40	Pin 5x40	1
39	000232000	Spannhülse 4x24	Pin 4x24	1
41	000223902	Unterlage A6 Zn	Washer A6 Zn	4
42	150275400	Mutter VM10	Nut VM 10	4
43	000221307	Mutter M10 8.8 Zn	Nut M10 8.8 Zn	2
44	154065807	Buchse	Sleeve	2
45	000209205	Schraube M8x30	Screw M8x30	6
46	150275302	Mutter VM8	Nut VM 8	A44,B46
47	000208509	Schraube M8x15	Screw M8x15	20
48	000257509	Schraube M8x20	Screw M8x20	5
49	150192204	Schraube M6x10	Screw M6x10	9
50	000250506	Mutter M6	Nut M6	5
51	000225900	Unterlage C10	Washer C10	2
52	000225508	Unterlage A14	Washer A14	1
53	000224108	Unterlage A8	Washer A8	A33,B35
54	150300301	Schraube A 4,2x13	Screw A 4,2x13	2
55	150317507	Schraube M8x16	Screw M8x16	A10,B12
56	000248903	Schraube M8x16	Screw M8x16	2
57	152150102	Unterlage 11/32-2	Washer 11/32-2	4

A= ROTO 175 D, ROTO 180 DS  
B= ROTO 215 D, ROTO 220 DS

Bild I Fig I

No. on the figure Numer anzeichn.	Catalogue no. Katalog nummer	Benennung	Description	Quantity Stück
1	154061204-549.07.021.0	Wälze schw.	Cylinder	A1
1	154070007-548.07.021.0	Wälze schw.	Cylinder	B1
2	153951003-543.07.134.0	Lagergehäuse	Bearing housing	2
3	153951101	Lager 172 6307 2RS	Bearing 172 6307 2RS	B2
4	154006603-549.07.026.0	Zinken Plast.	Plastic finger	A48,B70
5	000237602	Segerring 35	Circlip 35	2
6	150054103	Schmierpihl	Nipple	2
7	151020308-TN 01	Unterlage 35,2/43-0,9	Washer 35,2/43-0,9	A2
7	151020503-TN 01	Unterlage 35,2/43-1,5	Washer 35,2/43-1,5	B2
8	154062105-549.07.033.0	Zinkenkschelle	Clamp	A24,B35
9	150275400	Mutter VM 10	Nut VM 10	A24,B35
10	150335809	Schraube M10x50	Screw M10x50	A24,B35
14	150429904	Nilos 6307 schw.	Nilos 6307	4

A= ROTO 175 D, ROTO 180 DS  
B= ROTO 215 D, ROTO 220 DS

Bild J Fig J

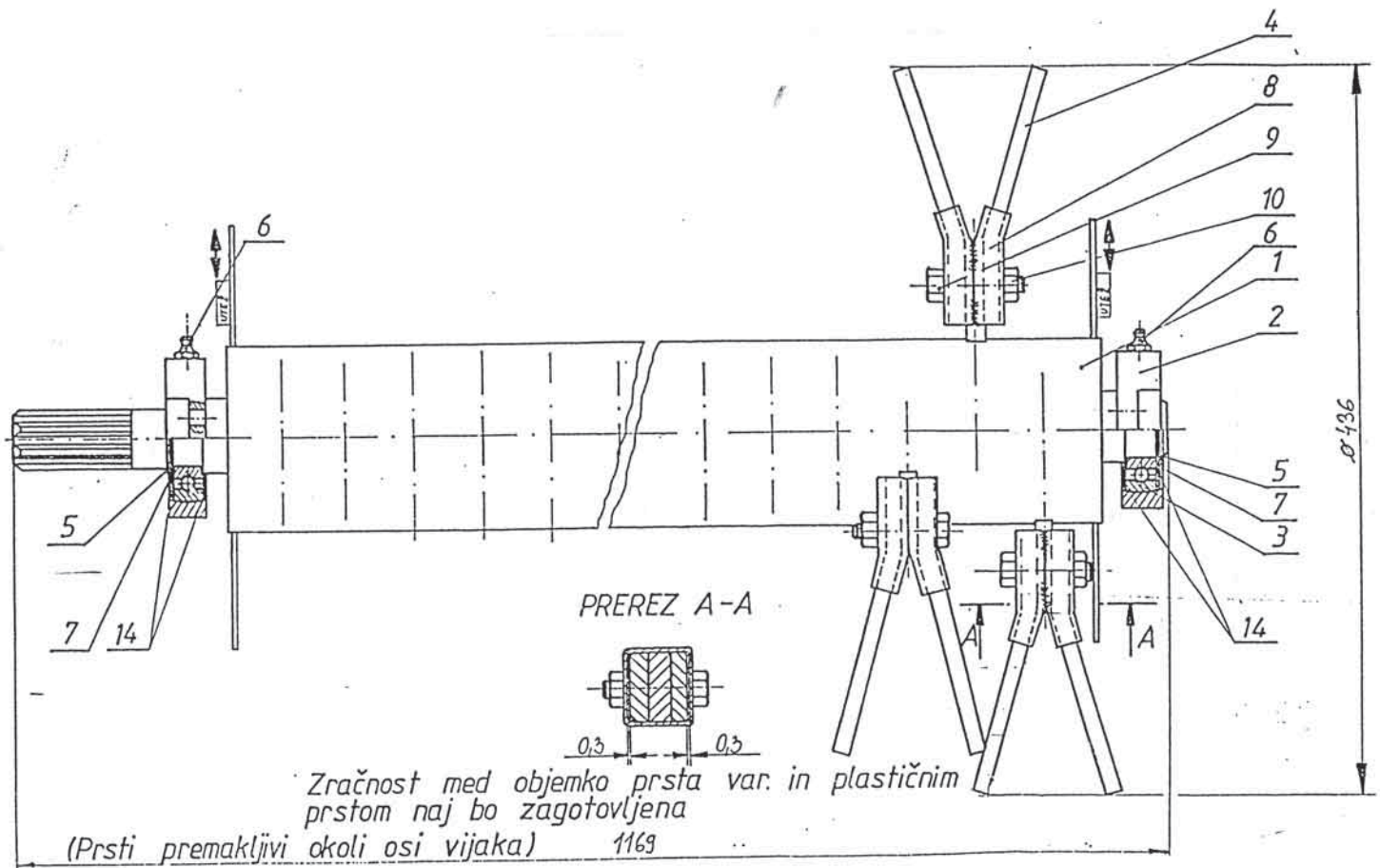

No.on the figure Numer anzeichn.	Catalogue no. Katalog nummer	Benennung	Description	Quantity Stück
1	154622803-548.08.010.0	Welle	Shaft	1
2	154064808-548.08.003.0	Kegelrad 3	Pinion 3	1
3	151394903-455.05.019.0	Antriebsgehäuse	Gear box	1
4	151915609-515.01.005.0	Scharnier schw.	Tube	1
5	154065406-548.08.010.0	Buchse 1	Sleeve 1	1
6	151916207-515.01.012.0	Platte 5	Platte 5	1
7	151916305-515.01.013.0	Platte 3	Platte 3	1
8	154064700-548.08.002.0	Kegelrad 1-28/3,8	Pinion 1-28/3,8	1
10	151012503-455.04.032.0	Dekel Plast.	Plastic cover	1
11	151014002-455.05.018.0	Unterlage 30,2/38-0,8	Washer 30,2/38-0,8	1
12	151014501-455.05.056.0	Unterlage 50/61,8	Washer 50/61,8	1
13	151203405-115.08.020.5	Schraube 6 M18x1,5	Screw 6 M18x1,5	1
14	151916403-515.01.014.0	Platte 3	Plate 3	1
15	151916500-515.01.016.0	Band 2	Band 2	1
18	000243105	Lager KR 6206 2 RS	Bearing KR 6206 2 RS	1
19	000243800	Lager KR 6207	Bearing KR 6207	2
20	150100802	Lager KR 6007 2 RS	Bearing KR 6007 2 RS	1
21	000212004	Schraube M12x30	Screw M12x30	2
22	000207608	Schraube M6x15	Screw M6x15	4
23	150087202	Schraube M12x25	Screw M12x25	4
24	000223207	Mutter M30x1,5	Nut M30x1,5	1
25	150160300	Mutter M12	Nut M12	2
26	000227908	Unterlage B6	Washer B6	4
27	000228505	Unterlage B12	Washer B12	4
28	150026607	Unterlage 30	Washer 30	1
29	000228603	Unterlage B12	Washer B12	2
31	000237602	Segerring 35	Circlip 35	1
32	000236300	Segerring 62	Circlip 62	2
33	000256001	Dubel A8x7x34	Cotter A8x7x34	1
34	150047103	Dichtungsring 35x72x12	Oil seal 35x72x12	1
35	150004907-FUCHS	Fett viskoma R	Grease	1,7 kg
36	151019908-TN 01	Unterlage 35,2/43	Washer 35,2/43	1
37	000230707	Dubel A8x7x45	Cotter A8x7x45	1
38	150275400	Mutter VM10 8 Zn	Nut VM10 8 Zn	1
39	150110203	Schraube M10x50 8.8 Zn	Screw M10x50 8.8 Zn	1

Bild K Fig K

